

Installation Instructions

URIMAT®

Important:

Make sure all the drainpipes are professionally cleaned when replacing existing urinals.

| | | |
|-----------------|--------|-----------------|
| eco | 15.001 | No Display |
| ecoplus | 16.001 | Static Display |
| ecoinfo | 11.001 | Backlit Display |
| ecovideo | 16.971 | Video Display |

URIMAT Ireland - ROI & NI
 GEMGATE Limited
 White Bay House
 Whitegate, Co. Cork, IRELAND
 Ph +353 (0)21 4 66 26 53
 Fax +353 (0)21 4 66 11 12
 info@urimat.ie / www.gemgate.ie

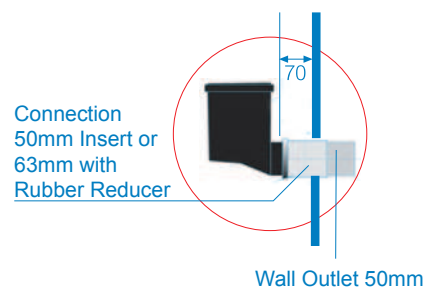
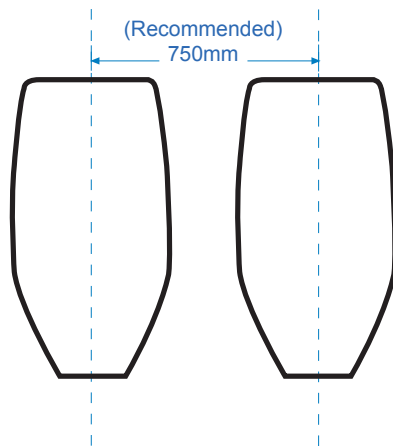
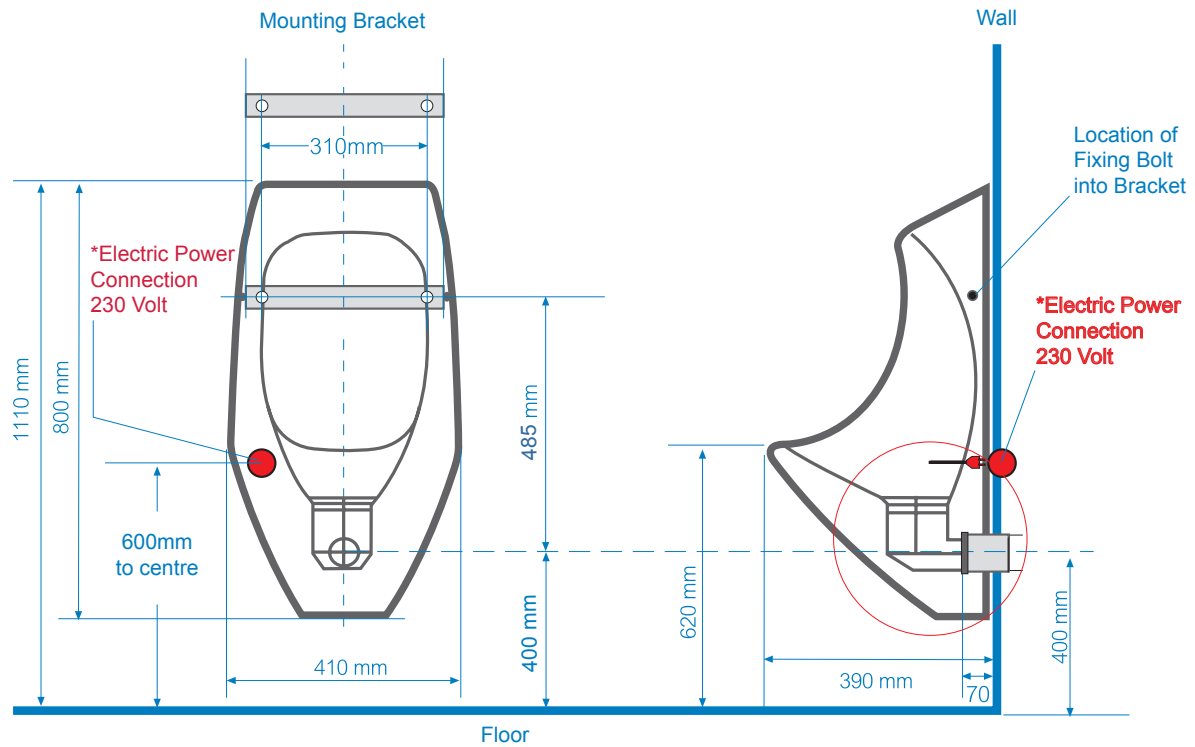

Installation Kit - Item No. 57.001



*Electric connection only applies to ecoinfo & ecovideo



Couplers for Irish Imperial waste pipe 1¼", 1½" & 2" available on request.
Outer rims of the coupler may have to be cut-off to ensure the urinal and wall-junction seal sit tightly up against the wall.

90° metric elbows 50mm x 50mm available on request for wastepipe fitted underneath the urinal.

Note: please ensure waste-pipe connection is properly sealed!

IMPORTANT: EU-Standard min. downgrade for wastewater pipes = 2%, i.e. 2cm per metre drainpipe, ideally 3%, but 5% maximum!



URIMAT eco, ecoplus, ecoinfo