

GEMAT 430 / GEMAT 430 NS

(NS = automatic level control) **CE**

Construction

<u>Casing</u>	EN 1.4301 (AISI 304)
<u>Suction Sieve</u>	EN 1.4301 (AISI 304)
<u>Impeller</u>	THERMOPLAST (PPE + PS – Glass fibre reinforced)
<u>Shaft with rotor</u>	EN 1.4305 (AISI 303) + AISI 303 ceramic coated shaft sleeve
<u>Motor frame with stator</u>	EN 1.4301 (AISI 304)
<u>Motor cover</u>	PP-GF30
<u>Seals</u>	<u>Mechanical seal</u> (pump side) + lip seal (motor side) – oil lubricated (ESSO Marcol 172)

<u>Mechanical seal</u>	Ceramic/Carbon/NBR
<u>Lip seal</u>	NBR
<u>O-Ring</u>	NBR
<u>Discharge</u>	G1 1/4" (FT)
<u>Temperature (max.)</u>	50°C – (recommended 35°C)
<u>Solids (max.)</u>	10 mm
<u>Cable length (Pump)</u>	10 m
<u>Cable material (Pump)</u>	H05RN-F
<u>Cable material (Float)</u>	H07RN-F
<u>Handle</u>	PP

Motor

<u>Voltage</u>	230 V ± 10%
<u>Phase</u>	1
<u>Power Input</u>	0,43 kW
<u>Power Output</u>	0,25 kW
<u>Full Load Current</u>	1,9 A
<u>Rotation speed</u>	~ 2800 min ⁻¹
<u>Insulation Class</u>	F
<u>Protection degree</u>	IP 68
<u>Capacitor</u>	Yes
<u>Thermal over-load protection</u>	Yes



Pump Picture merely serves illustration

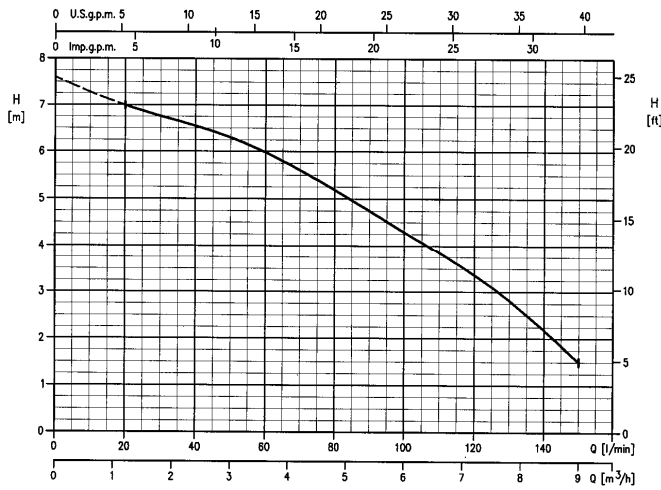

Performance Chart

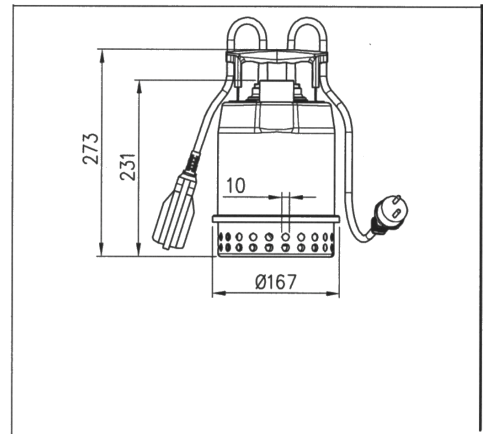

Dimensions (mm)

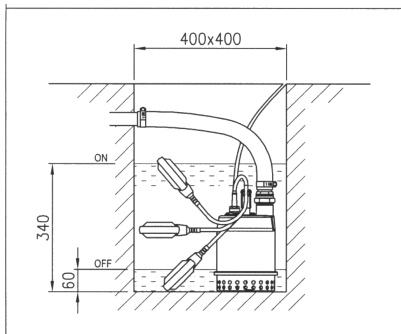

Installation (mm)

WITH MECHANICAL SEAL
MIT GLEITRINGDICHTUNG
AVEC GARNITURE MÉCANIQUE